

Pocket Doors

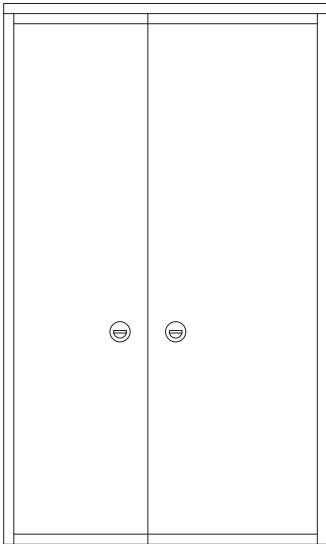

Type 2 Pocket Door Shown

Manual Operation Opening Height

& Width: Custom built to job site requirements.

PRODUCT OVERVIEW:

Hufcor offers pocket doors to close the openings of operable wall storage pockets.

It has been our experience that one of the types shown in these specifications will work for most pocket openings; however, if needed, they can be modified to suit a particular application.

Pocket doors are factory covered with the same material as the operable wall panels or may be manufactured unfinished for field decoration to match the perimeter walls.

Delivery: Doors are custom built for your specific project. Lead times vary due to seasonal fluctuations. Check with your Distributor for the current schedule.

Warranty: Pocket doors are guaranteed for **two years** against defects in material and workmanship.

"Standard" Product Features and Benefits:

Look for these features when comparing similar products.

- 1. Feature:** The operating mechanism is internal.
Benefit: Aesthetically pleasing and allows more space inside the pocket to stack panels.
- 2. Feature:** Adjustable Jambes
Benefit: Doors may be properly aligned for easy operation.
- 3. Feature:** Low profile hinges.
Benefit: Safety and aesthetics - no unsightly hinges protruding from the door jambes.
- 4. Feature:** Finish options.
Benefit: Aesthetics. The doors may match the partitions or the perimeter wall finish.
- 5. Feature:** Custom engineering.
Benefit: Doors can be designed to meet your specific job site requirements.



The standard product may be modified for optimum versatility. See details provided or just ask your Hufcor representative for the features you want.

GENERAL SPECIFICATIONS/POCKET DOORS

Pocket Doors

PART 1 - GENERAL

1.01 DESCRIPTION

A. General

- Operable wall manufacturer shall furnish and install pocket doors and provide all labor, materials, tools, equipment, and services for pocket doors in accordance with provisions of contract documents.

1.02 RELATED WORK BY OTHERS

- Preparation of opening will be by General Contractor. Any deviation of site conditions contrary to approved shop drawings must be called to the attention of the architect.
- All header, blocking, support structures, jambs, track enclosures, surrounding insulation, and sound baffles as required in 1.04 Quality Assurance.
- Paint or otherwise finishing all trim and other materials adjoining head and jamb of pocket doors.

1.03 SUBMITTALS

- Complete shop drawings are to be provided prior to fabrication indicating construction and installation details. Shop drawings must be submitted within 60 days after receipt of signed contract.

1.04 QUALITY ASSURANCE

- Preparation of the opening shall conform to the criteria set forth per ASTM E557 Standard Practice for Architectural Application and Installation of Operable Partitions.
- The manufacturer shall have a quality system that is registered to the ISO 9001 standards.

1.05 PRODUCT DELIVERY, STORAGE, AND HANDLING

- Proper storage of pocket doors before installation and continued protection during and after installation will be the responsibility of the General Contractor.

1.06 WARRANTY

- Pocket doors shall be guaranteed for two years against defects in material or workmanship.

PART 2 - PRODUCTS

2.02 MATERIALS

- Product to be (**select as required**): (Type 1) (Type 2) (Type 3) (Type 4) pocket doors as manufactured by Hufcor Inc.
 - Pocket door(s) shall be nominally 3" [76] thick.
 - Panel faces shall be laminated to appropriate substrate to meet the STC requirement. STC rating shall be determined by the partitions selected for use with the pocket doors.
Optional face material (Not all substrates are available for all STC ratings. Consult your Hufcor Distributor for more information):
Steel
Non-steel
Medium Density Fiberboard
 - Frames shall be of 16 gauge [1.42mm] painted steel with integral factory applied aluminum vertical edge and face protection. Optional: Face finish shall wrap around the vertical panel edges and provide no protective vertical face trim. This option is only available with steel faces.
 - Pocket doors at heights of 16'3" and over, without face steel, will have horizontal splice rail(s). Location and quantity of splice rails is dependent upon height of door.
 - Horizontal top and bottom seals shall be of continuous contact multi-ply vinyl sweepstrips. When the pocket doors are in the closed position, the seals shall contact an aluminum head member which extends across the pocket from the track to the pocket walls.
 - Pocket doors shall be secured in the closed position by the face-activated expanding internal mechanism.
 - The operating mechanism to be located approximately 46" [1168] from the floor in the door face.

- The top mechanism extends from the top rail of the pocket door and latches in the horizontal header.
 - A jamb plate shall be attached to the floor to capture the bottom mechanism.
- Hinges shall be of steel and project no more than 1/4" [6] beyond panel faces. Each pocket door "leaf" to have a minimum of four hinges.
 - Jambs shall be of 6063-T6 aluminum and be adjustable + or - 3/8" [9.5].
- Weight of the pocket doors shall be 5.7-8.9 lbs. per sq. ft. [27.8-43.5 kg/sq.m] based on sound rating of the partition selected.

C. Finishes

- Face finish shall be: (**select as required**):
 - Factory applied reinforced vinyl fabric with woven backing, weighing not less than 20 oz. per lineal yard [620 g/m]. Color shall be selected from manufacturer's standard color selectors.
 - Standard upgrade fabrics (color shall be selected from manufacturer's standard color selector):
 - Factory applied vertical ribbed carpet (N.R.C. .20)
 - Factory applied stain resistant fabric
 - Optional:
 - Customer selected (requires factory approval for manufacturing compatibility)
 - Unfinished for field decoration
 - Wood veneer (factory installed on models with edge protection)
 - High pressure laminate (factory installed on models with vertical edge protection.)
 - Exposed metal trim, jambs, and seal color shall be (**select from Hufcor's Standard Trim selector**):
 - Lamb's Wool (standard)
 - Brown (standard)
 - Gray (standard)
 - Custom powder coated (optional upgrade for metal trim)
 - Aluminum track shall be clear anodized
 - Optional upgrade:
 - Custom anodized
- Available Accessories/Options
 - Key lock - one side
 - Limit switches. Required for use with electric partitions. Limit switches are a safety feature which prevent the partition from operating until the pocket doors are completely open.

2.03 OPERATION

- Pocket doors shall be manually opened and closed.
- Pocket doors shall be secured in the closed position by the face-activated expanding internal mechanism.
- Pocket doors used with electrically operated partitions are to be equipped with limit switches which prevent the partition from operating until the pocket doors are completely open.

PART 3 - EXECUTION

A. Installation

The pocket doors will be installed by an authorized factory-trained installer and be in strict accordance with the approved shop drawings and manufacturer's standard printed specifications, instructions, and recommendations.

TYPE 1 - Not to Scale

Pocket Doors

Type 1 pocket door allows the operable wall to seal against the face of the pocket door. Leaf swings outward or inward and may be left or right handed.

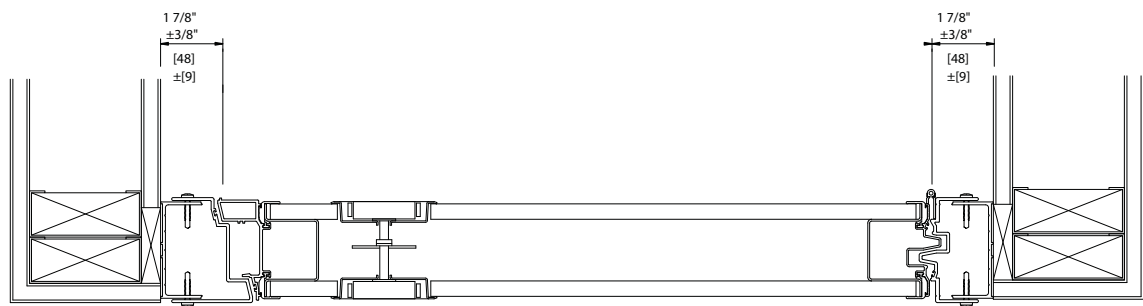
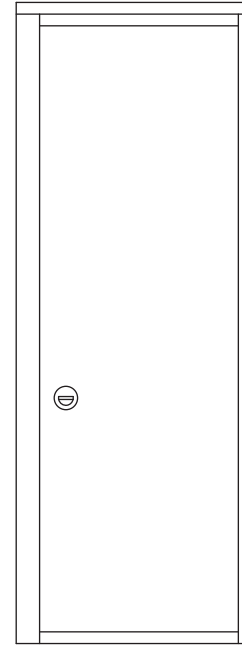
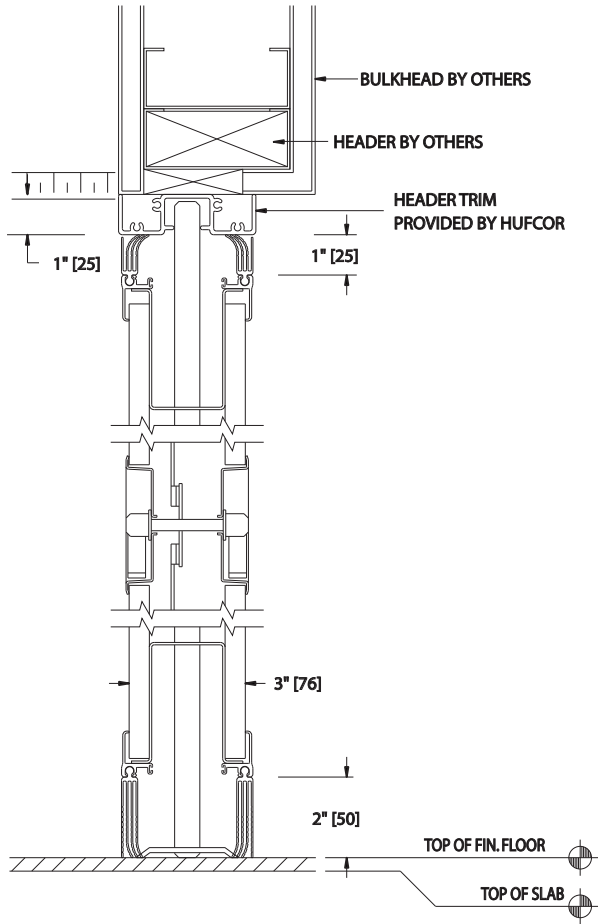
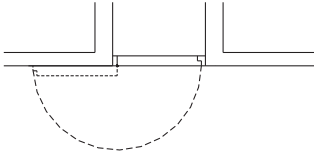

No Scale

TYPE 2 - Not to Scale

Pocket Doors

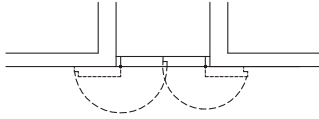

Type 2 pocket doors have two leaves and allow the operable wall to seal against the face of the pocket door. Both leaves swing outward or inward.

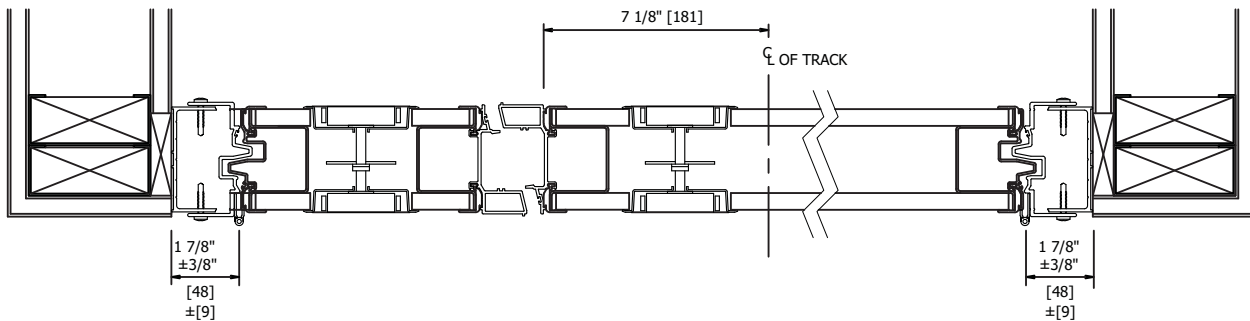
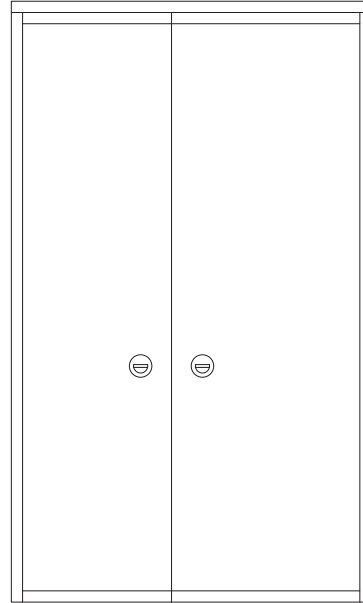
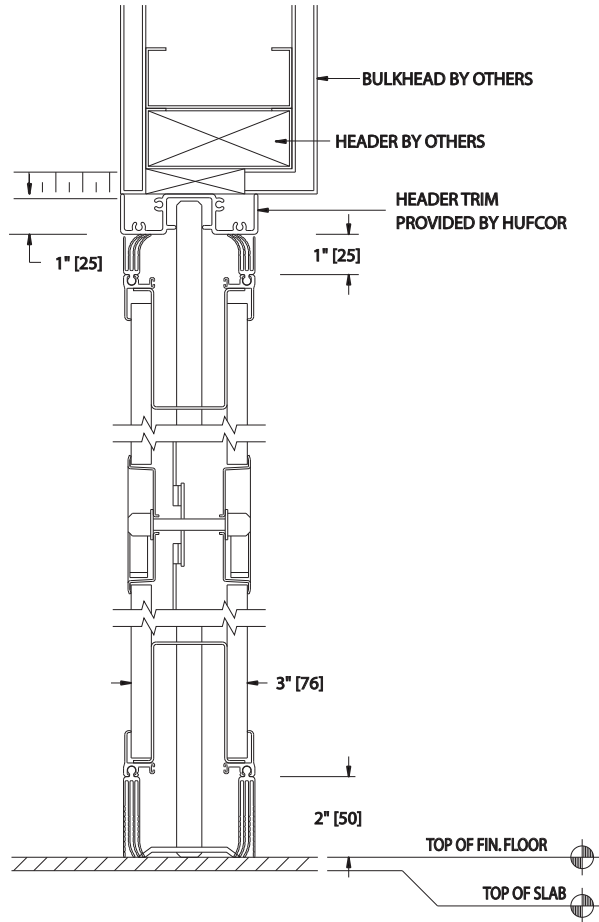

TYPE 3 - Not to Scale

Pocket Doors

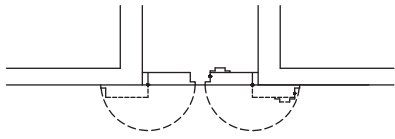

Type 3 pocket doors allow the operable wall to extend to the back wall of the pocket for optimum acoustics. Both doors (leaves) swing outward or inward. A narrow flipper panel completes pocket closure when doors are closed.

When used with electrically operated operable walls, pocket doors are equipped with limit switches. To prevent damage to the pocket doors, the limit switches will not allow the partition to operate until the pocket doors are completely open.

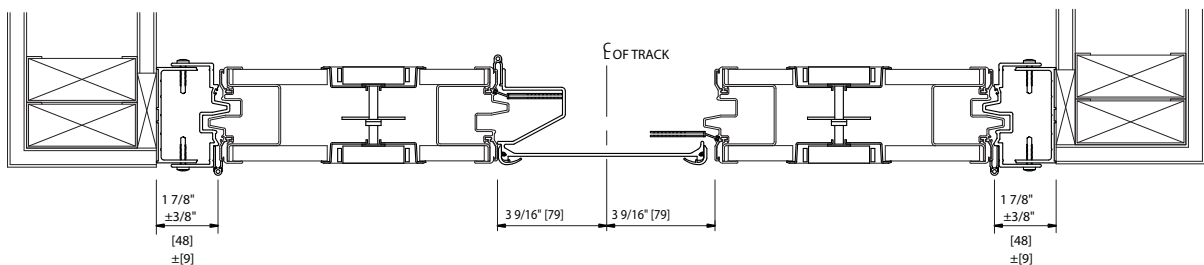
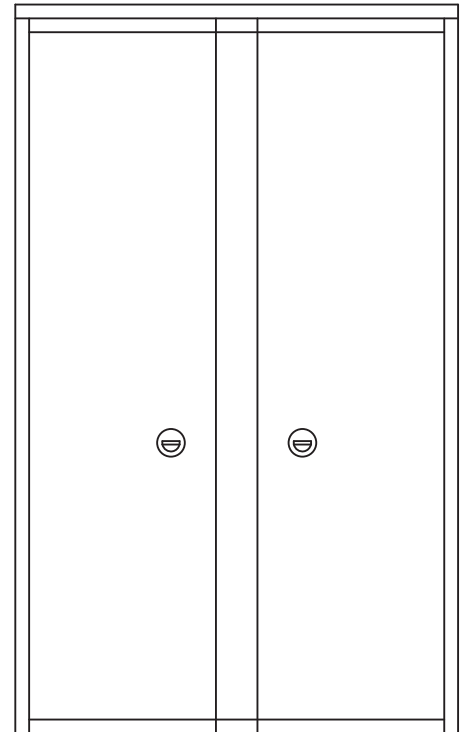
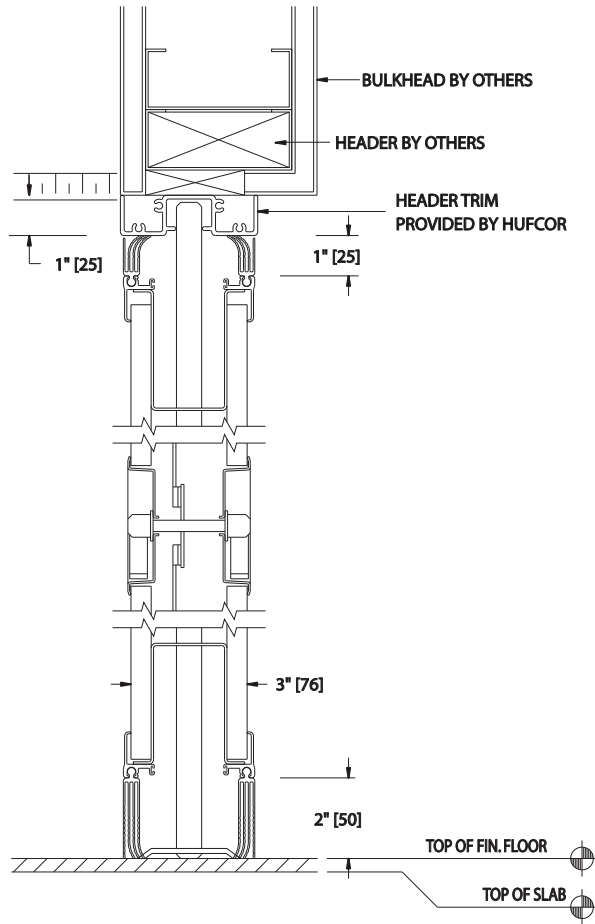

Type 4 pocket doors have two leaves and allow the operable wall to seal against the face of the pocket door. Both leaves are hinged together and swing outward or inward. Door can be left or right handed.

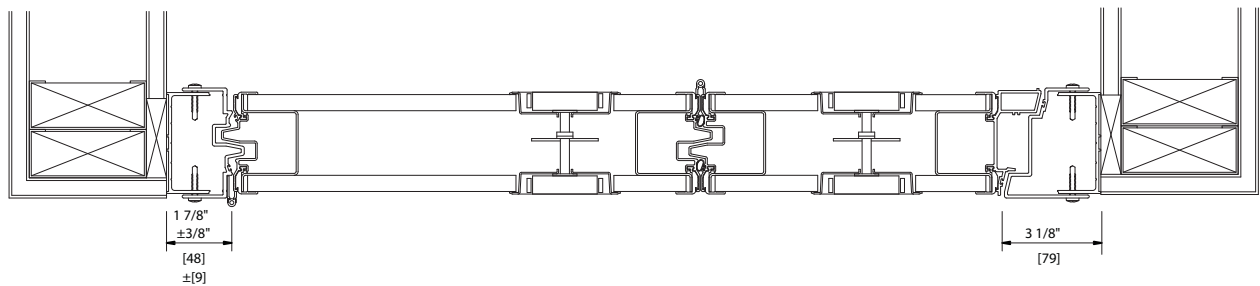
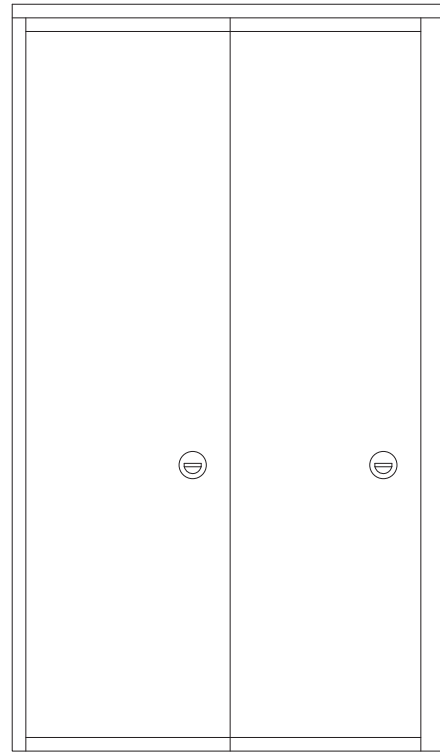
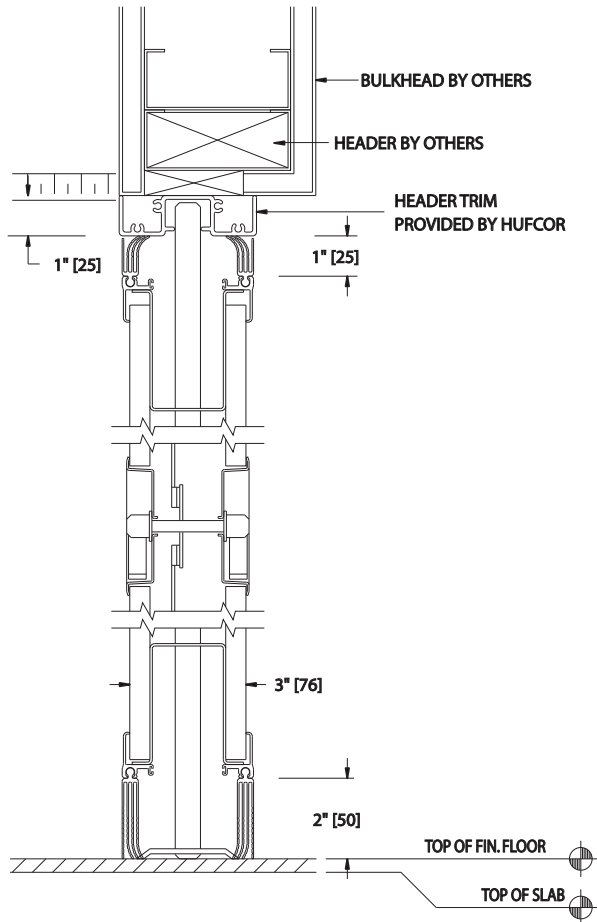
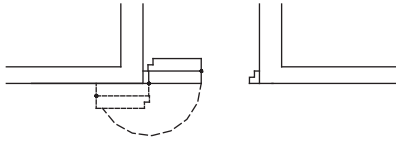

Worldwide headquarters:

Hufcor Inc.
 P.O. Box 5591
 Janesville, WI USA 53547-0591
 1-800-542-2371 ext. 214; 1-608-756-1241
 FAX: 1-608-758-8253
 E-mail: info@hufcor.com
 Website: www.hufcor.com

The manufacturer reserves the right to improve and change product without notice.